

SENSOR STK 476 PLUS



INNOVATIVE TECHNOLOGY
PROTECTION BY INFRARED
INTERNAL USE

STK-476 PIR Motion Detector

Installation Manual

The STK-476 is a state-of-the-art analogue detection system that incorporates the following unique features:

- Patented Auto Pulse® signal processing with two programmable levels
- Improved RFI rejection with metal shield
- Automatic Temperature Compensation
- High density reflow SMD design
- SAMTEK® wide angle (WA-1) standard lens

DO NOT TOUCH THE SENSOR SURFACE AS THIS COULD RESULT IN DETECTOR MALFUNCTION. IF NECESSARY, CLEAN USING A SOFT CLOTH AND PURE ALCOHOL.

COMMENCING INSTALLATION (FIG.1)

Select the detector's installation site, based on the required coverage and recommended height of 2.1m (7ft). Avoid proximity to any of the following: reflective surfaces, direct air flow from vents, fans and windows, sources of steam/oil vapor, objects causing temperature changes such as heaters, refrigerators, ovens, and infrared light sources. For CUL Listed applications, the unit shall be installed in accordance with Part 1 of the Canadian Electrical Code.

The detector comes equipped with the SAMTEK wide angle (WA-1) standard lens. For more information on the full range of MVA lenses, ask your local distributor for details. If another lens pattern is required, choose the desired lens and:

- a) remove front cover of the detector (1) by gently pushing in the cover pin (2) with a screwdriver.

- b) Pull out the bezel (4) by lightly pressing on bezel pin (5) and (6).
- c) Remove the lens and replace it with the alternate lens.

COVERAGE ADJUSTMENT

Using the SAMTEK standard lens at the recommended installation height of 2.1m (7ft) $\pm 10\%$, the STK-476 will provide full coverage from 1.2m (4ft) to 11m (35ft). Please ensure that the PCB is fixed at the 2.1m (7ft) mark. (A small vertical adjustment of the PCB ($\pm 0.5\text{mm}$) may be required. Refer to FIG-4 on other side)

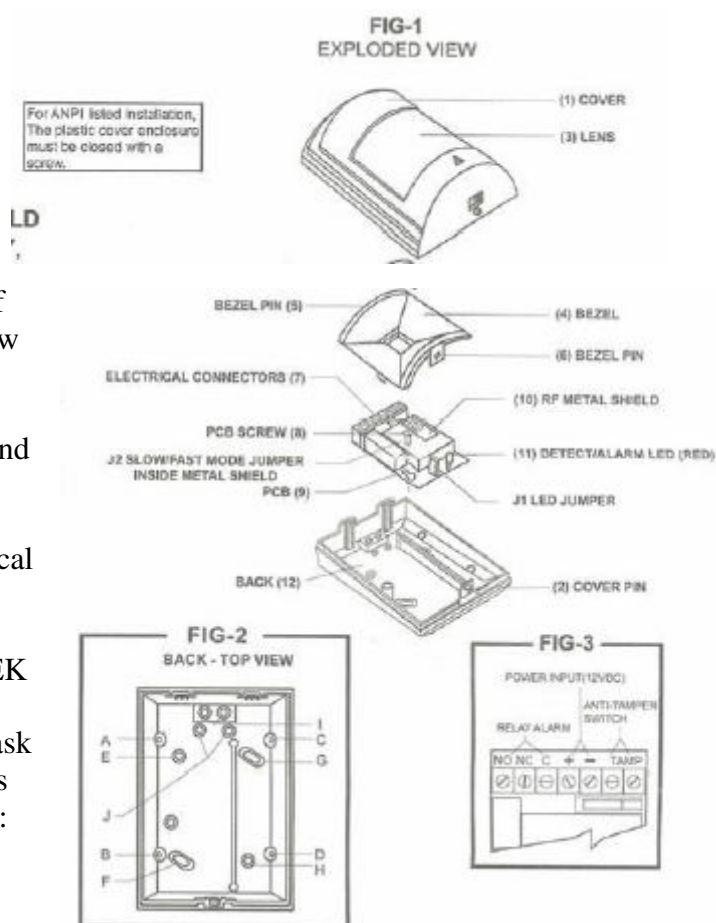

For any of the other SAMTEK lenses, please refer to pattern drawings for each lens. If another installation height is called for, move the PCB to the proper installation height indicated on the left side

of the PCB. A small adjustment may be required, depending on the protected area. Any PCB adjustment should be followed by a walk-test of the protected area. Walk-testing verifies that the required coverage is in place, as per the lens pattern being used. When walk testing, always move across the detection path, not toward the detector.

PET ALLEY

To create a pet “alley” using the pet alley lens, the recommended installation height is slightly above the maximum area occupied by the pet. The PCB should be set at the 2.1m (7ft) mark, regardless of the installation height for this lens.

LED SETTING (J1)

To disable the LED display, remove jumper J1 (see FIG-1).

SLOW/FAST MODE (J2)

Jumper J2 is located inside the metal shield and is factory-set to the “on” position (fast mode), which is recommended for the majority of installations. The use of slow mode (jumper “out” or “off”) is suggested in areas where the incidence of false alarms may be greater. To access Jumper J2, use a small screwdriver to gently pry off the metal shield (10). Please refer to FIG-1.

TURNING ON THE STK-476

Apply power by connecting the “AUX+” and “AUX-“of the control panel to the “+” and “-“ terminals of the detector (FIG-3). Powering the detector initiates a self-testing program for the signal processor, memory and relay. The green LED will flash for a period of 35 seconds and the relay will follow the status of the LED.

AUTO PULSE SIGNAL PROCESSING

Patented Auto Pulse® Signal Processing provides a variable pulse count rate, in response to signal shape, strength and width. The STK-476 will immediately generate an alarm for very strong signals, or switch automatically to pulse counting as signals become weaker. The STK-476 motion detector permits a very high pulse count rate (up to 6 or more) in the presence of low level signals.

AUTO TEMPERATURE COMPENSATION

These detectors are equipped with “automatic temperature compensation” (ATC), which adjusts amplifier gain to maintain coverage levels across a wide range of temperatures.

WALK-TESTING

In “fast” mode (J2=in), at 20°C, you should not be able to cross more than on complete zone (consisting of two beams left and right sensor detecting elements) in the coverage area with any kind of movement; slow/fast walking or running. In slow mode (J2=out), the amount of movement required to generate an alarm is doubled. The approximate width of a full beam at 10.6m (35ft) from the detector is 1.7m (6ft). Please note when the indoor temperature is higher than 25°C, the detection distance will be shorter.

IMPORTANT NOTES

The detector cover must be installed properly when conducting walk tests. The unit shall be tested annually by the installer in order to comply with UL-639. Only the WA-1 standard lens was tested to UL-639.

The unit is intended to be connected to a UL listed control unit or power supply which supplies a minimum of 4 hours of standby power.

WARRANTY

The Seller warrants its products to be free from defects in materials and workmanship under normal user for a period of one year. Except as specifically stated herein, all express or implied warranties whatsoever, statutory or otherwise, including without limitation, any implied warranty of merchantability and fitness for a particular purpose, are expressly excluded. Because Seller does not install or connect the products and the products may be used in conjunction with products not manufactured by Seller. Seller cannot guarantee the performance of the security system. Seller obligation and liability under this warranty is expressly limited to repairing or replacing, at Seller's option, any product not meeting the specifications. In no event shall the Seller be liable to the buyer or any other person for any loss or damages whether direct or indirect or consequential or incidental, including without limitation, any damages for lost profits stolen goods, or claims by any other party, caused by defective goods or otherwise arising from the improper, incorrect or otherwise faulty installation or use of the merchandise sold.

TECHNICAL SPECIFICATION

Sensor	Dual rectangular element, low noise, high sensitivity
Processing	Auto Pulse, two levels, temperature compensation
Startup	35 seconds
Detection Speed	0.2m-7m/sec (0.6-23 ft/sec.)
Detection Coverage	11m 110 degree
Operating Temperature	-10°C to +50°C (14°F to +122°F)
Power Input	12Vdc, 31mA maximum
Lens	2 nd generation Fresnel lens
Coverage	40'(12m) x 110° (standard lens)
Zones	22 = 9+5+5+3 (standard)
Mounting Height	7 – 9 ft (2m – 2.7m)
Alarm Indication	Green LED, constant light for 3 seconds
Alarm Output	N.C. 28Vdc / 0.15A
Anti-tamper Switch	N.C. 28Vdc / 0.15A Max
Humidity	95% maximum
Weight	80g (2.8oz)

